



MEETING STANDARDS IS OUR STANDARD
INSTALLATION, MAINTENANCE AND OPERATING INSTRUCTIONS
FULL PORT CLASS 150 FLANGED BALL VALVES

Flanged ball valves have been designed and engineered to provide you with long lasting trouble free service when used in accordance with the instructions and specifications mentioned herein.

INSTALLATION

1. Flanged ball valves are bi-directional and may be installed for flow in either direction. During installation it is recommended that the valve ball be in the open position in order to prevent any possible damage.
2. Install valve into pipeline and secure all flange bolts evenly. After installation, cycle valve several times before putting into service.
3. RECOMMENDED FLANGE BOLT TORQUES

VALVE SIZE	BOLT SIZE	RECOMMENDED BOLT TORQUE
6" – 8"	M20 (3/4")	295 ~ 305 N·m

4. Valves can't be used on unstable gases.
5. Max. working pressure is 275 psi (18.98 bar).
6. Max. working temperature is 200 °C (392 °F)

OPERATION

1. A quarter turn of the handle clockwise closes the valve and a quarter turn counterclockwise fully opens the valve. Visual indication of the ball position is determined by the handle position: when the handle is in line with the piping the valve is open, cross line the valve is closed. Also, the stopper indicates the direction of the ball port.
2. Soft seated ball valves perform best with the ball either fully open or fully closed in accordance with pressure/temperature chart. Consult the factory regarding characteristics of the media or pressure drop for applications other than fully open or closed.
3. Any media that might solidify, crystallize or polymerize should not be allowed to stand in the ball valve cavities. In the event that this should happen, **DO NOT** force the valve in either direction; disassemble and clean before resuming service.
4. Force required to break-away (i.e., force which must be exerted to begin motion of ball) will vary depending on the media, pressure and length of time between cycles.

The following data will act as a guide regarding break-away torques:

VALVE SIZE	MAXIMUM BREAK-AWAY TORQUE
DN150 (6")	220 N·m
DN200 (8")	500 N·m

The above figures were obtained at 25 degrees C., 7 bar after 24 hours.

5. The only mechanism of the valve that is adjustable is the stem packing. If adjustment is required the gland bolts may be fastened. Adjustment of the gland bolts should be no more than one-quarter turn at a time. Over tightening will produce high torque and a shortened seal life.

MAINTENANCE

A repair kit containing two seats, two body seals, one thrust washer and stem packing is available for rebuilding each size and style valve.

Be sure to specify size, style, seat and seal materials when ordering. Optional components are also available (ball, stem, handle, etc.).

Refer to illustration on backside for part identification and assembly.

REBUILDING

WARNING - Ball Valves Can Trap Fluids in Ball Cavity When Closed.

If the valve has been used to control hazardous media, it must be decontaminated before disassembly. It is recommended that the following steps are taken for safe removal and disassembly:

- Relieve the line pressure.
- Place the valve in half-open position and flush the line to remove any hazardous material from valve.
- All persons involved in the removal and disassembly of the valve should wear protective clothing such as face shield, gloves, apron, etc.

CAUTION: Exercise caution that sealing and all surfaces are not damaged during disassembly, cleaning or reassembly.

1. Before removing valve from line, rotate ball into the open position.
2. Remove valve from pipeline. Place valve on a clean surface and secure by clamping or bolting.
3. Unscrew the nuts and set aside. Take body and cap apart.
4. Remove body end seal, cap seat and bolts.
5. Rotate ball into the closed position. Remove ball and body seat.
6. If it is necessary to replace stem packing, remove snap ring, handle, stopper, gland bolts and gland. Lower stem into body cavity.
7. Clean and inspect all components to be sure they are free from foreign matter and pit marks, paying particular attention to areas that must maintain a seal (the surface against which the seats and body end seal are installed, finished diameter on stem, ball, stem hole). These areas must be free from scratches and pitting.
8. Light marring from the action of the ball against the seats is normal and will not affect the operation.
9. Once all components have been cleaned inspected and replaced as necessary, the valve may be rebuilt with the appropriate factory repair kit.
10. Slide new thrust washer over stem and insert assembly through ball cavity and fully up into stem hole recess.
11. Assemble new stem packing and screw the gland. Adjust stem packing to feel firm. **DO NOT over-tighten.**
12. Install stopper and snap ring.
13. Lightly lubricate ball and seats with a lubricant compatible with the media for which the service is intended.
14. Assemble new seat into body end and install ball into cavity, making sure that portholes are in desired position for operation. Once ball is engaged with stem, rotate to in-line position to prevent ball from falling out during assembly.
15. Insert body seal on seal surface of body cavity. Install second seat into cap cavity.
16. Screw bolts onto the body. Assemble cap and secure with nuts to the following recommended torque.
17. Assemble handle and snap ring.
18. Cycle valve open and close to ensure smooth operation.
19. Reinstall into service following the installation procedure.
20. If practical, check leak tightness before reinstalling valve inline.

NO	PART NAME	Q.TY
1	BODY	1
2	CAP	1
3	BALL	1
4	STEM	1
5	SEAT	2
6	GASKET	1
7	THRUST WASHER	1
8	PACKING	1
9	GLAND	1
10	STOPPER	1
11	SNAP RING	2
12	GLAND BOLT	2
13	BOLT	4
14	NUT	4
15	HANDLE	1

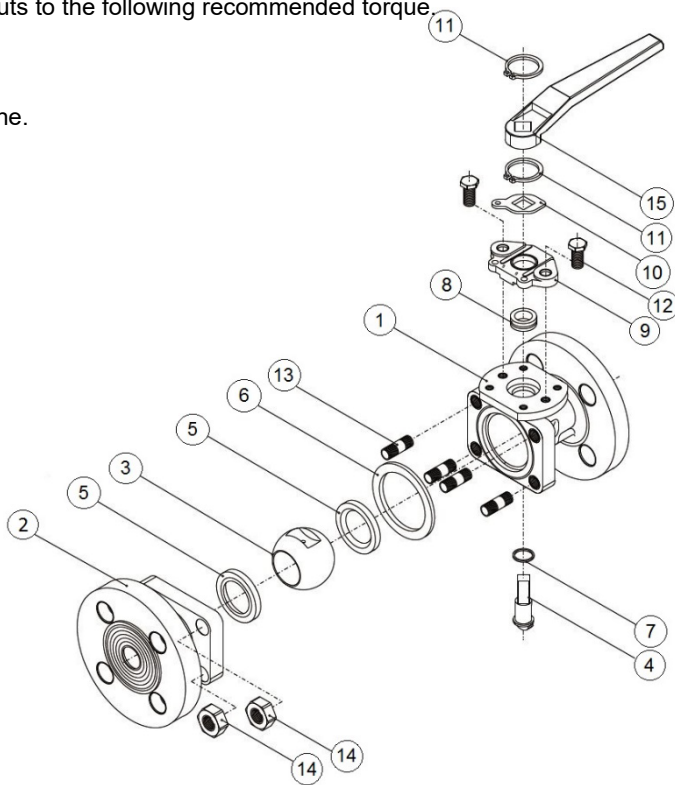

WARNING: This product can expose you to chemicals including lead which is known to the state of California to cause cancer and birth defects or other reproductive harm. For more information go to www.P65Warnings.ca.gov

RUB, INC.

4401 DEAN LAKES BLVD. SHAKOPEE, MN 55379-1896 (USA)

Phone 1+(952) 857-1114 Fax 1+(952) 857-1118

info@rubinc.com

www.rubinc.com