

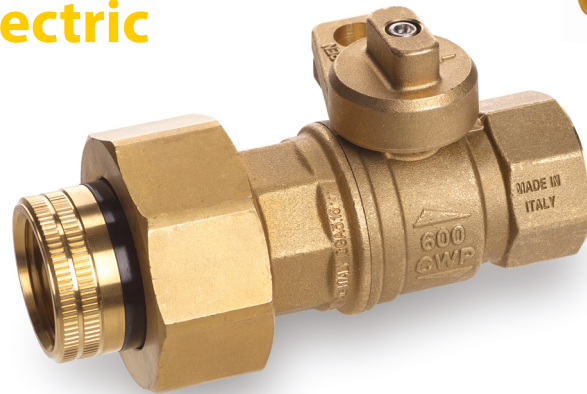

# s.8043 NPT dielectric

3/4" - 1 1/4"  
with tamper proof lockwing



## Quality

- 24h 100% seal test guaranteed
- No metal-to-metal moving parts
- No maintenance ever required
- Cover clearly shows ball position
- Silicone-free lubricant on all seals
- Chrome plated brass ball for longer life
- Handle stops on body to avoid stresses at stem

## Body

- Hot forged sand blasted, unplated brass body and cap sealed with Loctite® or equivalent thread sealant
- Special design to combine newest technologies in valve and traditional gascock requirements
- Finest brass according to EN 12165 and EN 12164 specifications

## Stem

- Blowout-proof unplated brass stem
- Maintenance-free, double FPM O-rings at the stem for maximum safety

## Sealing

- Pure PTFE self-lubricating seats with flexible-lip design

## Threads

- NPT taper ANSI B.1.20.1 female by dielectric union female threads

## Flow

- Full port to DIN 3357 for maximum flow

## Handle

- Hot forged brass tamper proof lockwing

## Working pressure & temperature

- 600 PSI (40 bar) non-shock cold working pressure
- 250 PSI (17 bar) non-shock working pressure for LP-Gas
- -40°F to +350°F (-40°C / +170°C)
- **WARNING:** freezing of the fluid in the installation may severely damage the valve

## Options

- Painted gray
- Dielectric union end long or short pattern

## Upon request

See s.80

## Approved by or in compliance with

- Underwriters Laboratories (United States, Canada):
  - Guide YSDT: LP-Gas shut-off valve
  - Guide YRBX: Flammable liquid shut-off valve
  - Guide YRPV: Gas shut-off valve for use with natural and manufactured gases
- Canadian standards Association (United States, Canada)
- GOST-R (Russia)
- RoHS Compliant (EU)
- Canadian standards Association (United States, Canada)

**NOTE:** approvals apply to specific configurations/sizes only.

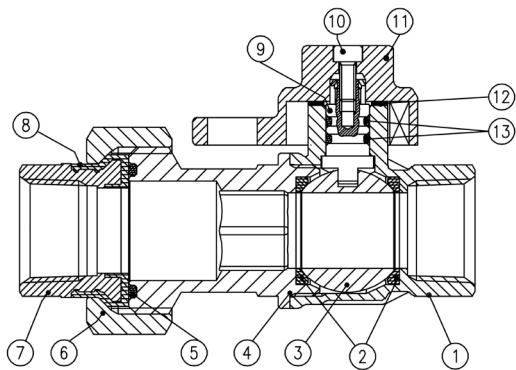

1 1/4" hollow ball

Part description	Q.ty	Material
1	1	CW617N
2	2	PTFE
3	1	CW617N
4	1	CW617N
5	1	FPM
6	1	CW617N
7	1	CW617N
8	1	Polyamide
9	1	CW617N
10	1	1.4301 / AISI 304
11	1	CW617N
12	1	PTFE glass filed 25%
13	2	FPM

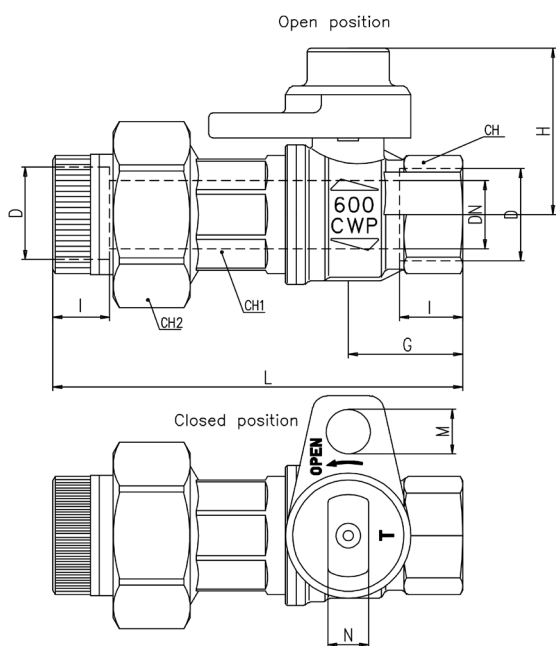

DN shows the nominal flow diameter.  
Actual flow diameter complies with full port DIN 3357 part 4.

Code	S80E43	S80F43	S80G43
D (inch)	3/4	1	1.1/4
DN (inch)	0.748	0.945	1.181
I (inch)	0.669	0.826	0.905
L (inch)	4.507	5.157	5.236
G (inch)	1.260	1.594	1.831
A (inch)	1.141	1.141	1.209
H (inch)	1.831	1.988	2.559
M (inch)	0.492	0.492	0.472
N (inch)	0.449	0.449	0.563
CH (inch)	1.220	1.575	1.929
CH1 (inch)	1.220	1.575	1.929
CH2 (inch)	2.047	2.401	2.441
Cv (GPM)	48.5	80.9	92.4

**Pressure-temperature chart**

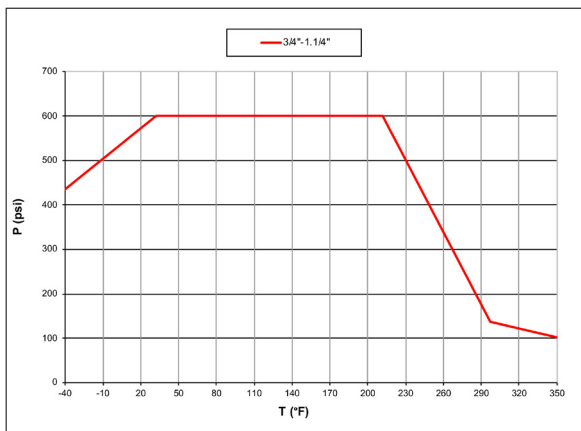
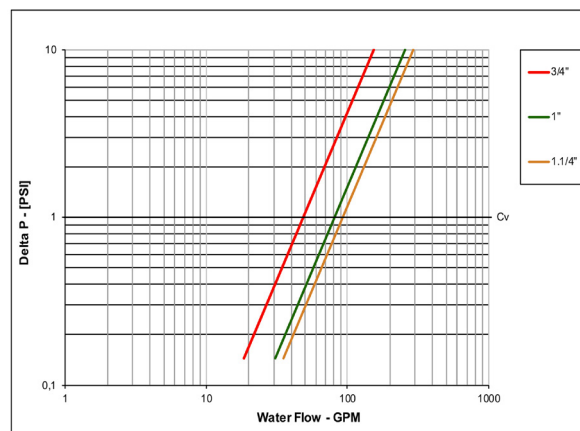

Chart applies to valve

**Pressure drop chart**



**WARNING:** This product can expose you to chemicals including lead which is known to the state of California to cause cancer and birth defects or other reproductive harm. For more information go to [www.P65Warnings.ca.gov](http://www.P65Warnings.ca.gov)

XCES8043 - 4314

RUB, Inc. - [www.rubinc.com](http://www.rubinc.com)